

Pedestal Paver System

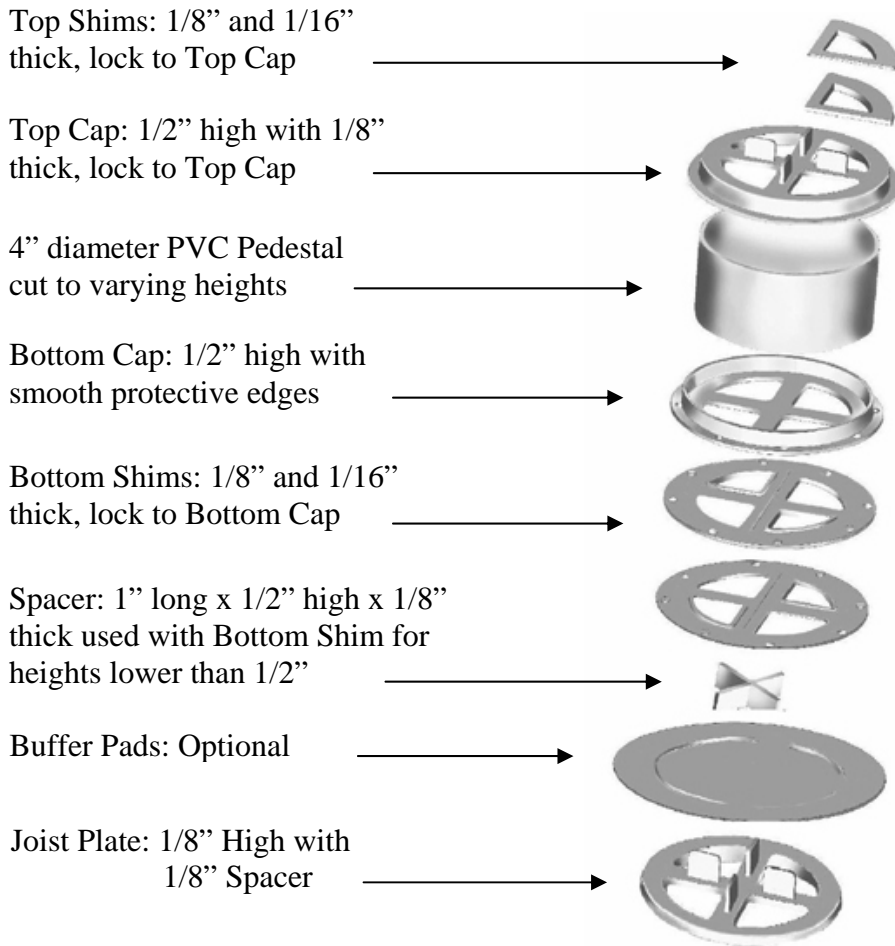

For proper heights lower than 1/2" the pedestal standard cross 1" long 1/2" high and 1/8" thick can be used with the pedestal standard 4"x 4" square shim, both in 1/16" and 1/8" thickness (though we recommend that if construction permits, it is always preferable to have at least a 1" gap under pavers to allow for airflow and water movement).

The 4" PVC used in the pedestal system is 3034. It is an off-the-shelf product, standard in North America with the outside dimension of 4.215" which matches the inside diameter of the pedestal top and bottom cap.

The (3034) PVC 4.210" OD 5" up to 27" compression tested 11,000 to 13,000 PSI (NOTE: all testing done with both top and bottom pedestal caps in place.)

Formula for Calculating Pedestals

Example No.1

Materials used:

20" x 20" Eurogranite Slabs (2.78 SF per paver)

Square Feet Coverage

1000 SF (20' x 50')

Formulas:

1,000 SF/2.78 SF = 360 Pedestal & Pavers needed

Calculation of Perimeter (Lineal feet)

20' x 50' area = 140 lineal foot perimeter

140' x 12" = 1,680"

1,680" / 20" (length of paver) = 84 pedestals

Total: 360 + 84 = 444 pedestals needed

Example No.2

Materials used:

16" x 16" Eurogranite Slabs (1.73 SF per paver) **Square Feet**

Coverage

800 SF (20' x 40')

Formulas:

800 SF/1.73 SF = 463 Pedestal & Pavers needed

Calculation of Perimeter (Lineal feet)

20' x 40' area = 120 lineal foot perimeter

120' x 12" = 1,440"

1,440" / 16" (length of paver) = 90 pedestals

Total: 463 + 90 = 553 pedestals needed

Calculation of perimeter should include inner spaces such as planters!

Installation Details & Hints

- Each top shim is designed to snap in to the top cap. Each bottom shim snaps into the bottom cap, they can stack to provide additional height.
- Bottom shims are scored and can be broken in half using the one-half as a shim under the low side on a severely sloped roof system. You are only building up the low side with this application.
- In a triangle or non-90 degree corner you can use a bottom cap in place of the top cap. You are getting the same elevation (1/8") but do not have to fool with the tabs on the top cap. Two bottom caps work well if you need to support the center of a large paver. It gives you a flat top in this application.
- Do you have less than a two-inch clearance at a threshold? Start that row out using either a top cap on a buffer pad (5/8" profile) or if even less is needed you can start that row with a joist plate on the buffer pad (1/4" profile).
- Always spec a buffer pad on a waterproof membrane. It prevents the ABS bottom cap from ever creating a wear spot on the membrane. This is your insurance policy against a call back years down road.
- The installation crews normally work in four man teams. One keeps the pavers supplied to the installation site. One runs the chop saw and does the entire PVC cutting. PVC is usually cut for each new row as needed. You count how many intersections will need pedestals, measure in a couple of locations to get the height right and call out to the cutter how many at what length are needed. Two paver installers are setting and leveling.
- Pedestal orders are normally calculated with up to a 5% override. This gives the installer enough parts to cover for unexpected corners, planter boxes that never show up on the drawing, bump outs that are created by framers who needed a little room for a drain chase and so on. Overnight shipping and lost installation time is much more costly in the long run.
- As a rule we spec top and bottom cap, buffer pad and one 1/8" and one 1/16" top shim for every pedestal. We use 1/8" bottom shims on about 1/5th of the pedestals and then no more than half that amount of 1/16" bottom shims.

PEDESTAL SYSTEM SPECIFICATIONS GUIDE

PART 1 GENERAL

1.1 SUMMARY

- A. Section Includes: Pedestal system used to support precast concrete [and stone pavers] set on pedestals, over waterproofed decks [pressure-treated wood joists].
- B. Related Sections:
 - 1. Division 2 - Unit Pavers
 - 2. Division 3 - Cast-in-Place Concrete: Concrete slab substrate.
 - 3. Division 6 – Rough Carpentry: Pressure-treated lumber used for floor joists, at exterior decks when using the pedestal joist plates
 - 4. Division 7 - Fluid Applied Waterproofing: Waterproofing under exterior pavers over occupied spaces.
 - 5. Division 7 - Bituminous Sheet Waterproofing: Waterproofing under exterior pavers over occupied spaces

1.2 REFERENCES

- A. American Society for Testing and Materials (ASTM)
 - 1. ASTM D 638 - Tensile Properties of Plastics
 - 2. ASTM D 790 - Flexural Properties of Unreinforced and Reinforced Plastics and Electrical Insulating
 - 3. ASTM D 1525 -Vicat Softening Temperature of Plastics

1.3 QUALITY ASSURANCE

- A. Installer: Company with no less than three (3) years documented experience in the installation of exterior pedestal mounted pavers.

1.4 SUBMITTALS

- A. Make submittals in accordance with Section 01330 or other applicable section in Division 1.
- B. Samples:
 - 1. Pedestals: Submit sample of each type of pedestal.
 - 2. PVC Pipe: Submit 12-inch long sample of PVC pipe.
- C. Shop Drawings: Show general layout of paved areas, and layout of pedestal system, including sloped conditions; include dimensions, edge details, adjacent construction, and special conditions.

1.5 DELIVERY, STORAGE, AND HANDLING

- A. In accordance with 01600 or other applicable section in Division 1.
- B. Store pedestal support system and pavers on platforms a minimum of 4 inches off the ground. Cover with polyethylene and protect from contact with materials which would cause staining or discoloration.

1.6 WARRANTY

- A. Submit in accordance with Section 01770 or other applicable section in Division 1.

B. The contractor performing this work, warrants that their work will remain free from defects of labor and materials used in conjunction with their work in accordance with the general conditions for this project, or for a maximum period of three (3) years, whichever is less.

PART 2 PRODUCTS

2.1 MANUFACTURER

A. Paver Pedestal System: Tile Tech Pedestal System, as manufactured by Tile Tech Pavers, 213 380-5560, www.TileTechPavers.com Pedestal system consists of pedestals and caps, including “snap-fit” top and bottom shims and leveling plates, as required for adjustment and leveling of pavers; each pedestal tested to support at ultimate failure compression load of 11,500 psi , with maximum height of 22 inches, per the Lab Test No. E77612, performed by Northwest Laboratories, Seattle WA, on December 2, 2003. Lab test results as follows:

SUBMITTED: 4" SDR 35/ASTM D3034 PVC Pipe - Paver Pedestals With End Cap

TEST METHOD: Per Customer's Instructions Load Per End Use Condition

TEST RESULTS: (Sample Conditioning – 68 degrees F)

<u>Sample</u>	<u>Sample Length (in.)</u>	<u>Load, Lbs.</u>	<u>Failure Mode</u>
1	1.5	11,930	PVC Pipe
2	2.0	11,730	PVC Pipe
3	4.0	11,740	PVC Pipe
4	6.0	11,810	PVC Pipe
5	8.0	11,900	PVC Pipe
6	10.0	11,650	PVC Pipe
7	12.0	11,670	PVC Pipe
8	14.0	11,650	PVC Pipe
9	16.0	11,740	PVC Pipe
10	18.0	11,050	PVC Pipe
11	20.0	10,085	PVC Pipe
12	22.0	11,500	PVC Pipe

2.2 MATERIALS

A. Pavers: As specified elsewhere in the Project Manual.

2.3 COMPONENTS

A. Top Cap: ½-inch high with 1/8-inch joint spacers; ABS plastic composed of Dow “ABS 70” plastic meeting following physical properties:

1. Characteristics:

- a) 6300 psi Tensile strength at yield, when tested in accordance with ASTM D 638.
- b) 350,000 psi flexural modulus, when tested in accordance with ASTM D 790.
- c) 10,500 psi flexural strength, when tested in accordance with ASTM D 790.
- d) 226 degrees F., vicat softening point, when tested in accordance with ASTM D 1525.
- e) Ozone Resistant.

- B. Bottom Cap: ½-inch high with smooth protective edges; ABS plastic composed of Dow “ABS 70” plastic meeting following physical properties:
1. Characteristics:
 - a) 6300 psi Tensile strength at yield, when tested in accordance with ASTM D 638.
 - b) 350,000 psi flexural modulus, when tested in accordance with ASTM D 790.
 - c) 10,500 psi flexural strength, when tested in accordance with ASTM D 790.
 - d) 226 degrees F., vicat softening point, when tested in accordance with ASTM D 1525.
 - e) Ozone Resistant.
- C. Top and Bottom Shims: 1/8 and 1/16-inch thick, lock to top and bottom caps; ABS plastic composed of Dow “ABS 70” plastic meeting following physical properties:
1. Characteristics:
 - a) 6300 psi Tensile strength at yield, when tested in accordance with ASTM D 638.
 - b) 350,000 psi flexural modulus, when tested in accordance with ASTM D 790.
 - c) 10,500 psi flexural strength, when tested in accordance with ASTM D 790.
 - d) 226 degrees F., vicat softening point, when tested in accordance with ASTM D 1525.
 - e) Ozone Resistant.
- D. Spacers: 1-inch long x ½-inch high 1/8-inch thick used with bottom shim for heights lower than ½-inch; ABS plastic composed of Dow “ABS 70” plastic meeting following physical properties:
1. Characteristics:
 - a) 6300 psi Tensile strength at yield, when tested in accordance with ASTM D 638.
 - b) 350,000 psi flexural modulus, when tested in accordance with ASTM D 790.
 - c) 10,500 psi flexural strength, when tested in accordance with ASTM D 790.
 - d) 226 degrees F., vicat softening point, when tested in accordance with ASTM D 1525.
 - e) Ozone Resistant.
- E. Buffer Pads: Thermoplastic Elastomer (TPE) “Kraton”, meeting minimum physical requirements of following tests:
1. Tensile strength and elongation, break at 830psi, and elongation at break minimum of 270% per ASTM D 412
 2. Tear resistance of 18psi, per ASTM D 624
 3. Shore Hardness (A Scale): 70.
- F. Pedestal Joist Plate: 1/4-inch high with 1/8-inch joint spacers; ABS plastic composed of Dow “ABS 70” plastic.

2.4 COMPONENTS – SEPARATELY SUPPLIED BY INSTALLER OR OTHERS

- A. Pedestal Pipe (NOT supplied with pedestal components by Tile Tech Pavers): 4-inch diameter PVC sewer pipe, type SDR 35 meeting ASTM D-3034 and F-679; provide pipe for use in the pedestal system, meeting following physical properties:
- a. Characteristics: 4.215 inches outside diameter; 3.890 inches inside diameter.
- B. Protection Course:
1. Protection board (required over insulated BUR systems, and when specified for use over bituminous asphalt-based waterproofing): W.R. Meadows “Vibraflex” or equal, minimum 3/8- inch thick asphaltic composition protection board.

2. Insulation (when specified): Dow Styrofoam “Highload 100” or equal, minimum compressive strength of 100 psi recommended for foam plastic insulation placed beneath Pedestal System to prevent damage to the waterproof membrane.

2.5 PERIMETER CONTAINMENT AND SUPPORT

- A. The complete assembly of insulation (if used), protection board (if used), drainage mat (if used), pedestals and pavers must be restrained at the perimeter of the walk deck area. Cumulative movement in excess of 1/8 inch will void the Tile Tech Pavers Pedestal System warranty. Perimeter parapet walls, concrete dividers or other perimeter restraint must be capable of resisting lateral forces (including seismic and wind).

PART 3 EXECUTION

3.1 EXAMINATION

- A. Prior to starting work, carefully inspect installed work of other trades and verify that such work is complete to the point where work of this Section may properly commence. Notify the Architect in writing of conditions detrimental to the proper and timely completion of the work.
- B. Do not begin installation until all unsatisfactory conditions are resolved. Beginning work constitutes acceptance of site conditions and responsibility for defective installation caused by prior observable conditions.
- C. Verify that substrates, membranes, and protection boards are ready for installation of pedestal system, and pavers.
 1. The substrate that is to receive pedestals shall have positive slope to provide adequate drainage in accordance with good building practices.
 2. Inspect to insure that all substrates have been properly prepared to accept the pedestals. Any surface defect which may impair performance of the pedestals or waterproofing membrane shall be appropriately repaired. Commencement of work shall imply acceptance of surfaces.

3.2 PREPARATION

- A. Establish accurate lines, levels, and pattern .
- B. Assure that the surface to accept the pedestals is clean and free of debris which would impair the performance of the pedestal system.
- C. Insulation and/or protection board must be applied over the waterproofing/roofing substrate. If specified, drainage mat, insulation and/or protection board must be installed according to manufacturer’s recommendations. If protection is specified only under the pedestal, then each pad must extend beyond the edge of the Pedestal System bottom cap or Buffer Pad, by a minimum of 2-inches.

3.3 PEDESTAL SYSTEM INSTALLATION

A. GRID LAYOUT AND ELEVATIONS

1. Layout the paver and pedestal grid layout, starting point and finished elevations in accordance with approved shop drawings which have been reviewed by the A/E or Designer, installing Contractor and Owner's Representative.

B. LEVEL INSTALLATION

1. Establish starting point and finished elevation of the paver surface, the support system elevation (finished elevation less the paver thickness) is established and marked around the perimeter using transit, water level or laser leveling device.
2. Take measurements, and provide two (2) perpendicular chalklines "snapped" on the surface to receive the pedestals. Use these lines as a reference to check the paver layout during installation and to assure a square layout. Installation of pavers can now begin, one row at a time.
3. At the starting row of pavers, a pedestal must be placed where each grid line meets the perimeter. Remove two spacer tabs in line with one another from atop each Pedestal System top cap, located along the perimeter. Adjust each to the elevation marked on the perimeter.
4. Position the pedestal as close to the edge of the perimeter as possible, with the two remaining spacer tabs aligned with the grid line. Using the elevation marked on the perimeter, stretch a mason's line along and slightly ahead of the second row of pedestals. A laser leveling device may also be used for this purpose.
5. Top Shims: Slight irregularities in paver thickness and/or deck heights, can be compensated for by using one or more of four pie-cut segments of Top Shims which is placed under a paver corner(s) atop the Top Cap at intersection quadrants.
6. Bottom Shims: Slight irregularities in paver thickness and/or deck heights (with additional slope requirements), can be compensated for by using one or more of the Bottom Shims which is placed below the Bottom Cap.
7. Buffer Pads and Protection Board: Install Buffer Pads and 12" x 12" x 3/8" thick protection board (W.R. Meadows "Vibraflex") below each Bottom Cap of the pedestal assembly, when installing the Pedestal System over:
 - a) Built-Up roofing (BUR) membranes that are installed over rigid or semi-rigid insulation;
 - b) Elastomeric type waterproof and/or roofing membrane coatings, so as to prevent damage to the membrane or coating system;

C. SLOPED INSTALLATION

1. Compensation to maintain a level paver surface over sloping substrates, can be accomplished using a combination of the following:
 - a) PVC Pipe length cut to varying lengths to compensate for slope;
 - b) Bottom Shims: Place one or more Bottom Shims under the Bottom Cap, to compensate for up to 1 inch per foot of slope.
 - c) Top Shims: Place the Top Shims (pie-shaped pieces) on to the Top Cap, in increments of 1/16 inch to precisely level the top on substrates with slope of up to 5/8 inch per foot.

D. PERIMETER CONTAINMENT

1. Any section of paver, pedestal or protection course which is not restrained by an abutting wall or parapet must be "boxed in" by some field installed restraint. No movement should be allowed at the perimeter of a paver system greater than 1/8 of an inch.

E. PEDESTAL JOIST PLATE SYSTEM

1. Joist Plate is placed directly on a 4x6 treated wood joist (or where existing deck joists are 2x6 or 2x 8, "sister" another treated wood 2x to the sides of existing joists).
2. Joist Plate serves as a spacer both horizontally and vertically, at each quadrant of the paver or gauged natural product (stone or equivalent) suitable for a walking surface.

3. Screw or nail in, but with a stabilized edge restraint (perimeter containment – see paragraph above) for the pavers, and at the proper spacing for the pavers will serve to align and level pavers which are applied directly to wood joists.
 - a. If the pavers are an inconsistent depth, or the wood is not exactly level, the top and/or bottom shims can be used to adjust for the inconsistency.
4. The Joist Plate System can be used over built up roof decks where fixed heights are allowed, 1/8” above membrane.

3.4 PAVER INSTALLATION

- A. Install pavers in accordance with paver manufacturer’s written instructions. Carefully align the Top Cap joint spacers with paver edges. Level pavers in each succeeding row.
- C. Install pavers tightly butted into pedestals. Form minimum joint widths.
- D. Shim or adjust to level and as necessary to prevent rocking of pavers.
- E. Installation Tolerances:
 1. Step in Face Alignment Between Paver Faces: Plus or minus 1/16 inch.
 2. Jog in Joint Alignment Between Paver Sections: Maximum 1/16 inch.
- F. Do not use pavers with chips, cracks, voids, stains, or other defects which might be exposed to view in the finished work.
- G. Machine cut pavers as necessary to fit the conditions indicated. Joints shall be no wider than the typical paver to paver joint.

3.5 FIELD QUALITY CONTROL

- A. Continuing and Final Inspection: Inspect often during installation to assure that grid (spacer) lines are straight and consistent, and that pavers are level, and where necessary, install Top or Bottom Shims; confirm that heights in excess of fifteen (15) inches have been braced in accordance with Tile Tech Pavers written instructions.

3.6 CLEANING

- A. Clean soiled surfaces using solution which will not harm concrete pavers. Consult paver supplier for recommended type.
- B. Use non-metallic tools in cleaning operations.

END OF SECTION

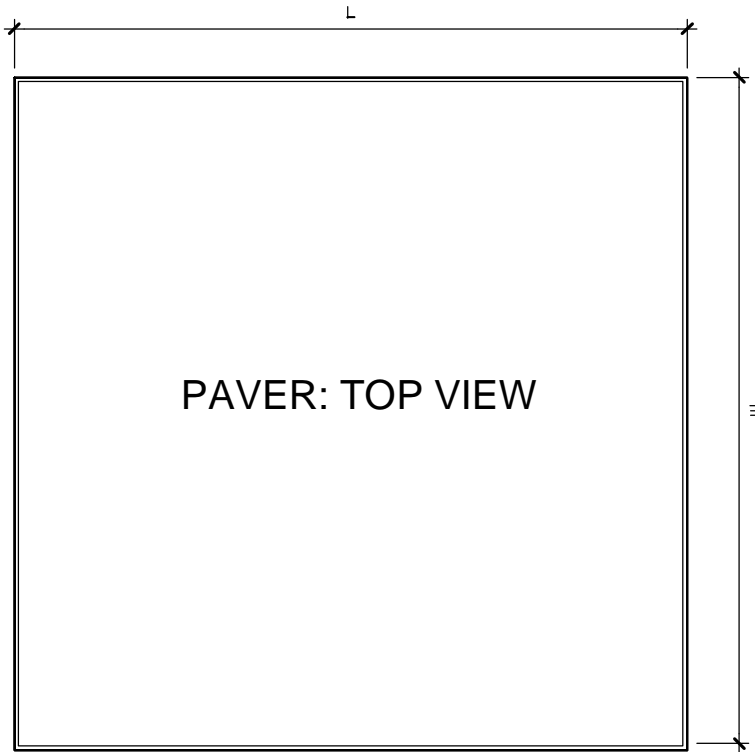

L	W	H
11 $\frac{7}{8}$ "	11 $\frac{7}{8}$ "	1"
11 $\frac{7}{8}$ "	11 $\frac{7}{8}$ "	2"
11 $\frac{7}{8}$ "	23 $\frac{7}{8}$ "	1 $\frac{3}{8}$ "
15 $\frac{3}{4}$ "	15 $\frac{3}{4}$ "	1 $\frac{1}{4}$ "
15 $\frac{3}{4}$ "	15 $\frac{3}{4}$ "	1 $\frac{1}{2}$ "
19 $\frac{5}{8}$ "	19 $\frac{5}{8}$ "	2"

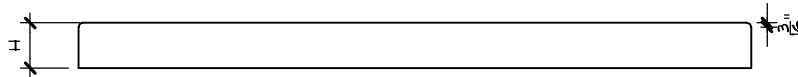

ARCHITECTURAL PAVERS PAVER SIZES

DRAWN BY: O100 DESIGN

DATE DRAWN:

REVISION DATE:

DRAWING SCALE: N.T.S



P. O. BOX 5982
LOS ANGELES, CA 90055
TEL: 213-380-5560 FAX: 213-380-5561
www.TileTechPavers.com

DIMENSIONS

GENERAL DETAILS

ENGINEER SEAL:

TOP SHIMS: $\frac{1}{8}$ " & $\frac{1}{16}$ " THICK
LOCK TO TOP CAP

TOP CAP: $\frac{3}{8}$ " HIGH

4 $\frac{1}{4}$ " OD PVC PIPE CUT
TO VARYING HEIGHTS

BOTTOM CAP: $\frac{3}{8}$ " HIGH

BOTTOM SHIMS: $\frac{1}{8}$ " & $\frac{1}{16}$ " THICK
LOCK TO BOTTOM CAP

BUFFER PADS: $\frac{1}{8}$ " THICK

JOIST PLATE $\frac{1}{8}$ " THICK

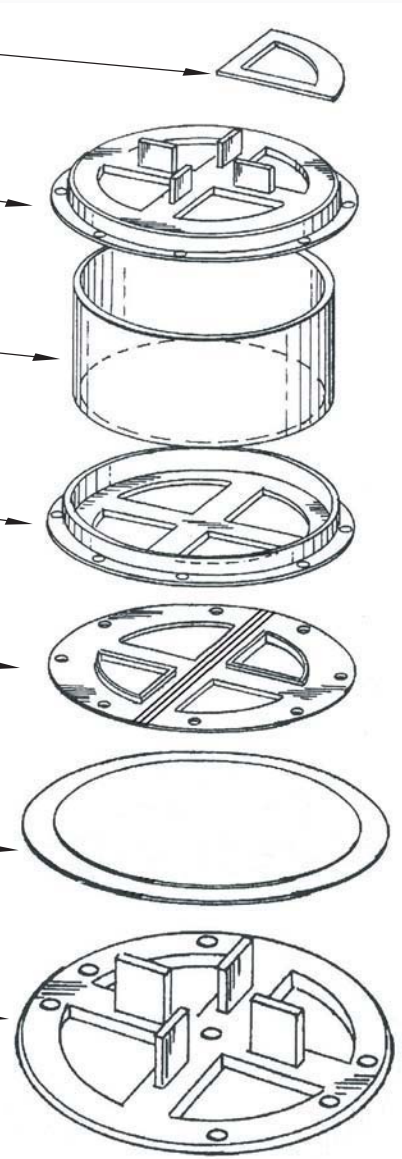

TOP CAP: TOP VIEW

5 $\frac{1}{2}$ " DIAMETER

SPACING TAB $\frac{1}{8}$ "

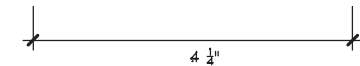
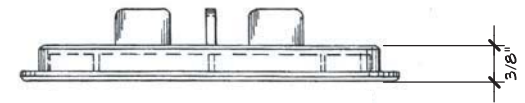
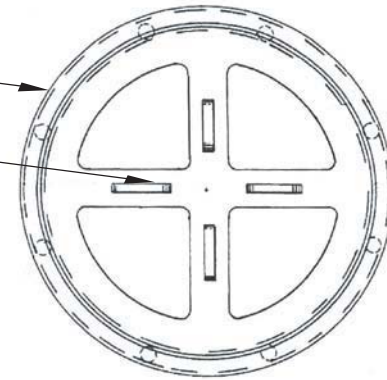

TOP CAP: SIDE VIEW

PEDESTAL SYSTEM ADJUSTABLE HEIGHT

DRAWN BY: O100 DESIGN

DATE DRAWN:

REVISION DATE:

DRAWING SCALE: N.T.S

ENGINEER SEAL:



P. O. BOX 5982
LOS ANGELES, CA 90055
TEL: 213-380-5560 FAX: 213-380-5561
www.TileTechPavers.com

DIMENSIONS

GENERAL DETAILS

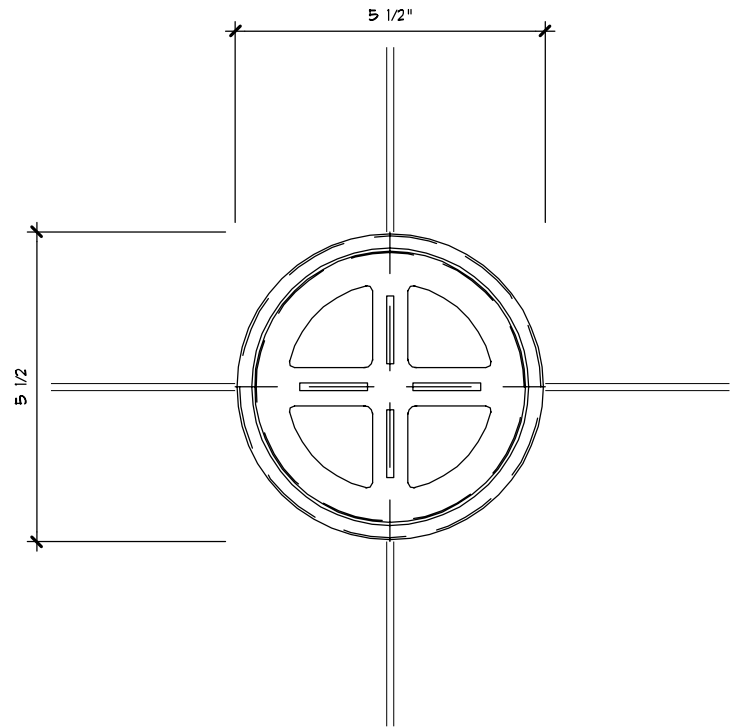
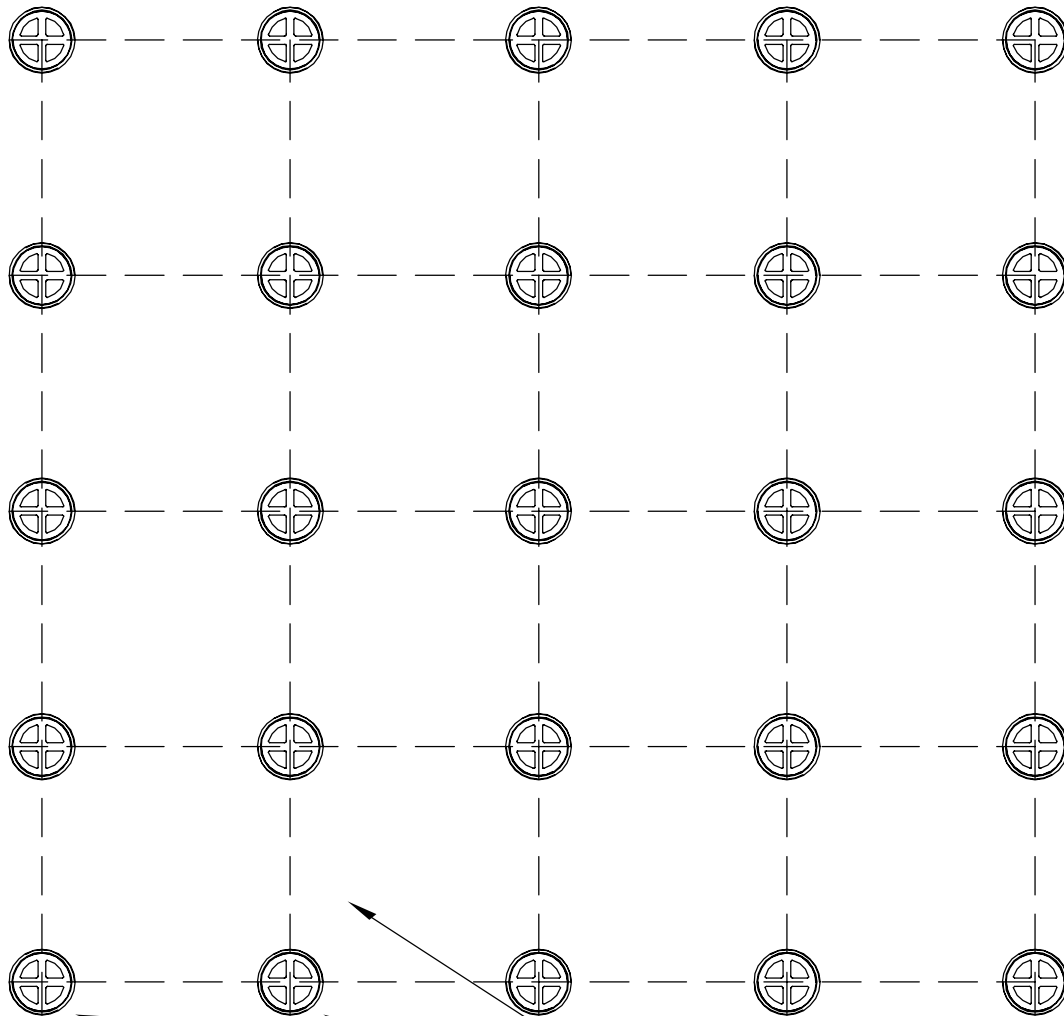

TILE TECH PAVERS
 ELEVATE PAVERS WITH TILE
 TECH APPROVED PEDESTAL
 SYSTEM

PEDESTAL PAVER SYSTEM LAYOUT PATTERN

DRAWN BY: O100 DESIGN

DATE DRAWN:

REVISION DATE:

DRAWING SCALE: N.T.S

ENGINEER SEAL:



P. O. BOX 5982
 LOS ANGELES, CA 90055
 TEL: 213-380-5560 FAX: 213-380-5561
 www.TileTechPavers.com

SQUARE PATTERN

SQUARE PAVERS

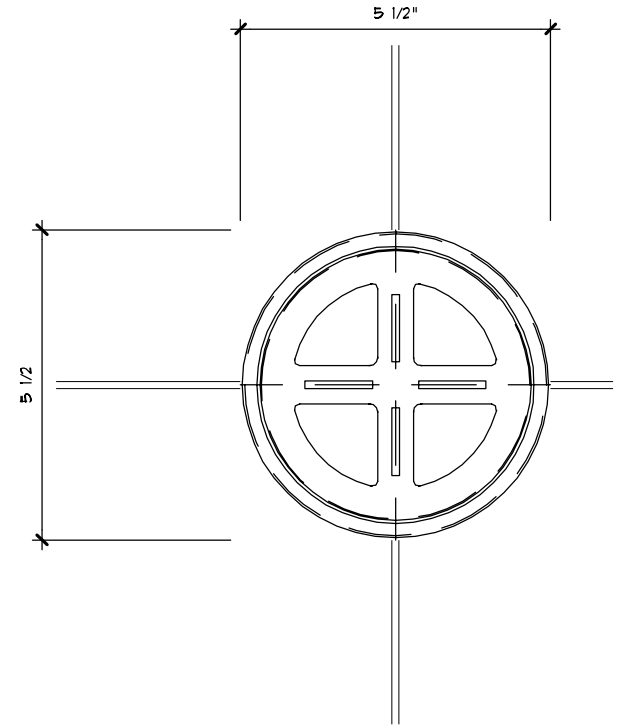
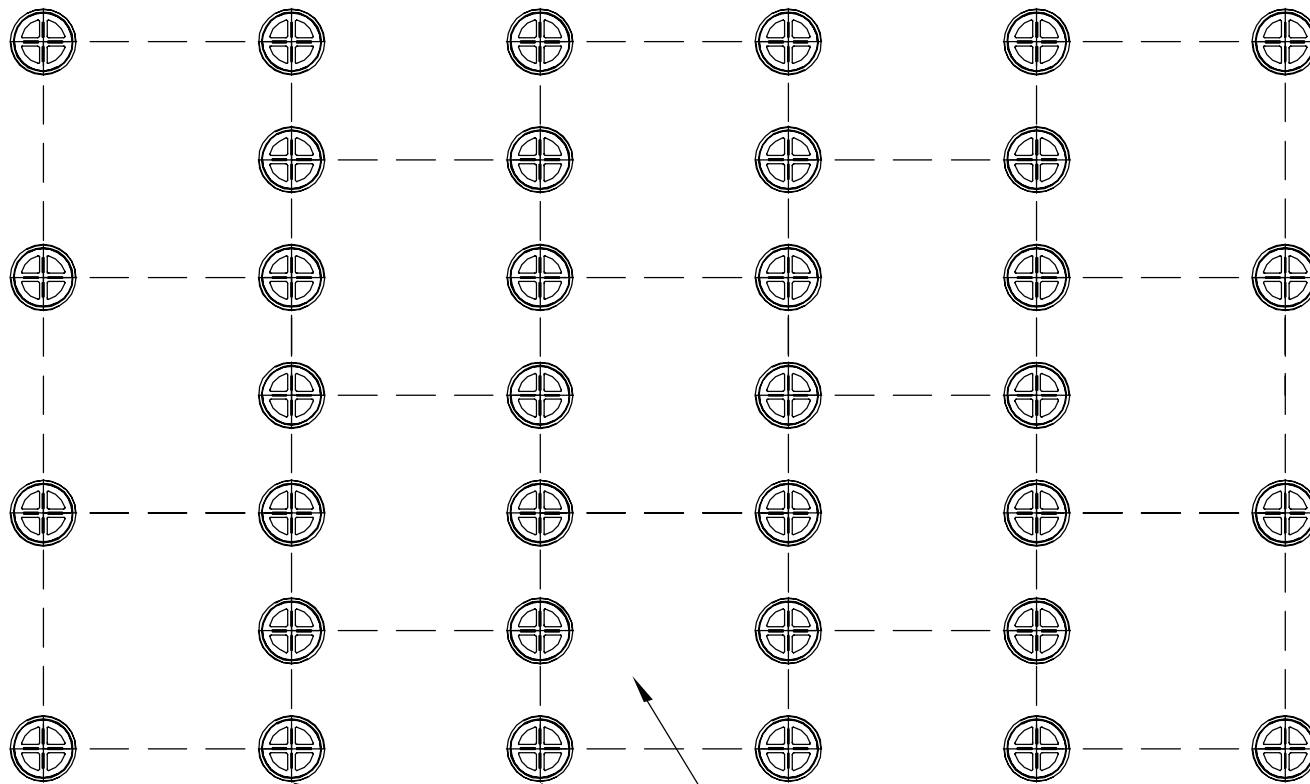

TILE TECH PAVERS

ELEVATE PAVERS WITH TILE
TECH APPROVED PEDESTAL
SYSTEM

PEDESTAL PAVER SYSTEM LAYOUT PATTERN

DRAWN BY: O100 DESIGN

DATE DRAWN:

REVISION DATE:

DRAWING SCALE: N.T.S



P. O. BOX 5982
LOS ANGELES, CA 90055
TEL: 213-380-5560 FAX: 213-380-5561
www.TileTechPavers.com

STAGGERED PATTERN

SQUARE PAVERS

ENGINEER SEAL:

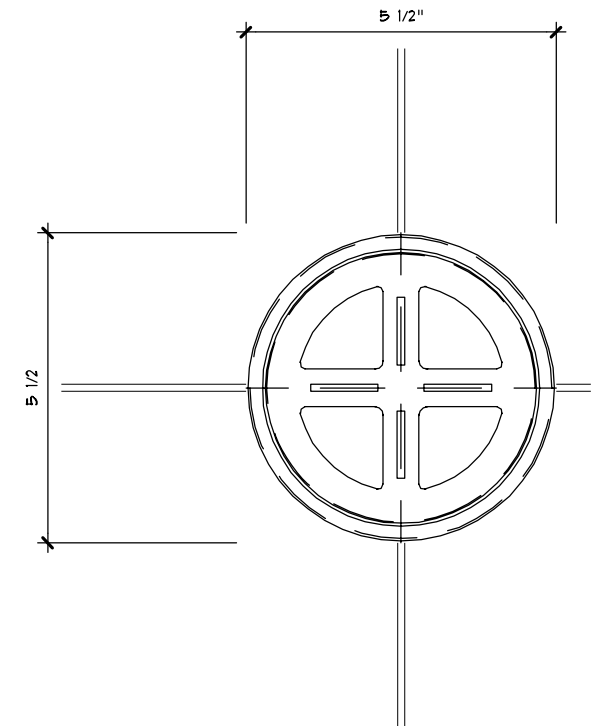
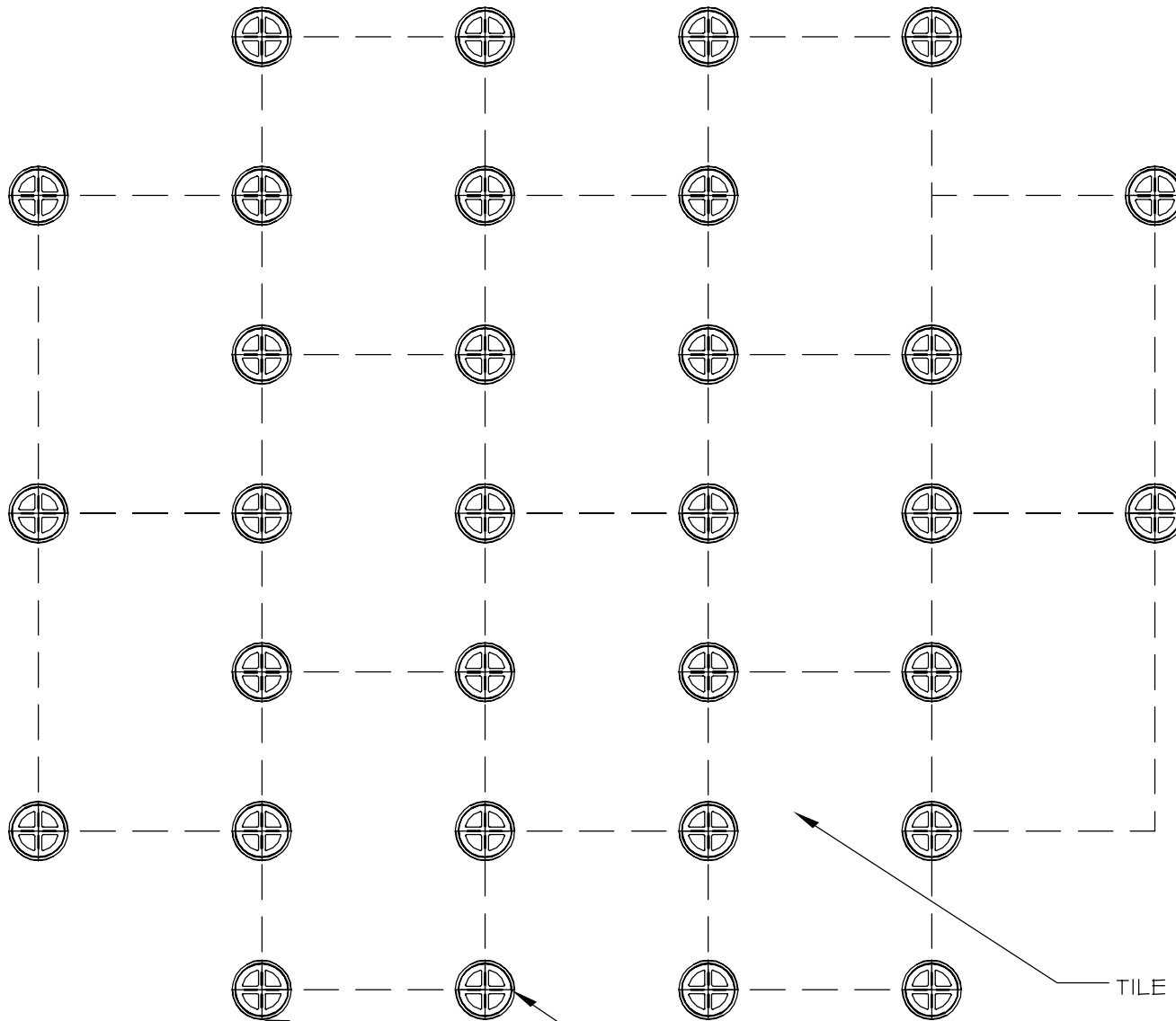

TILE TECH PAVERS

ELEVATE PAVERS WITH TILE
TECH APPROVED PEDESTAL
SYSTEM

PEDESTAL PAVER SYSTEM LAYOUT PATTERN

DRAWN BY:	O100 DESIGN
DATE DRAWN:	
REVISION DATE:	
DRAWING SCALE:	N.T.S

ENGINEER SEAL:



P. O. BOX 5982
LOS ANGELES, CA 90055
TEL: 213-380-5560 FAX: 213-380-5561
www.TileTechPavers.com

STAGGERED PATTERN

RECTANGULAR
PAVERS

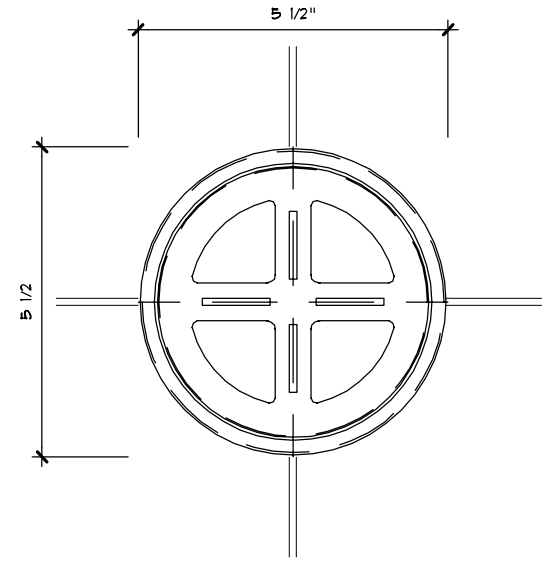
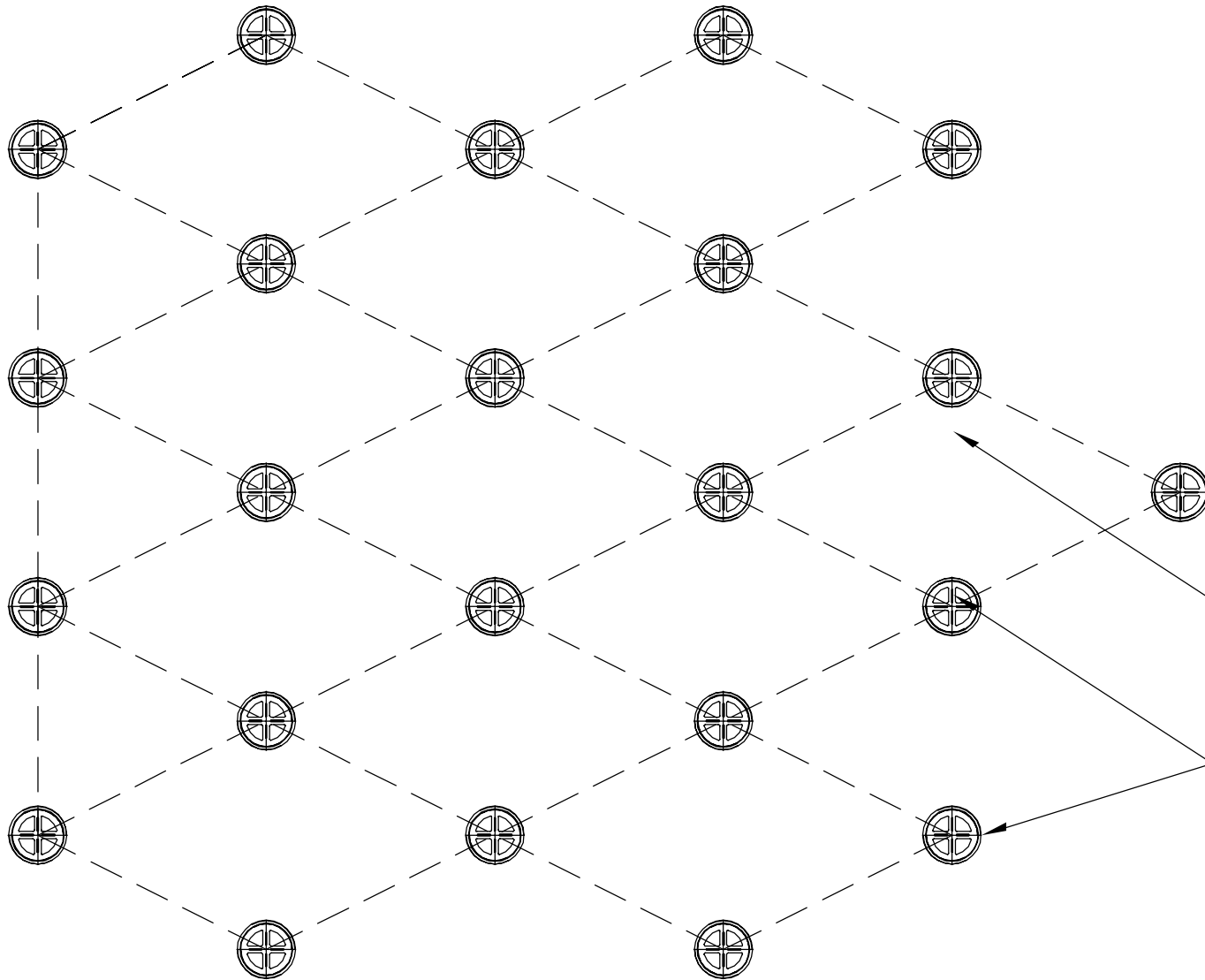

TILE TECH PAVERS

ELEVATE PAVERS WITH TILE
TECH APPROVED PEDESTAL
SYSTEM

PEDESTAL PAVER SYSTEM LAYOUT PATTERN

DRAWN BY: O100 DESIGN

DATE DRAWN:

REVISION DATE:

DRAWING SCALE: N.T.S

ENGINEER SEAL:



P. O. BOX 5982
LOS ANGELES, CA 90055
TEL: 213-380-5560 FAX: 213-380-5561
www.TileTechPavers.com

DIAMOND PATTERN

SQUARE PAVERS

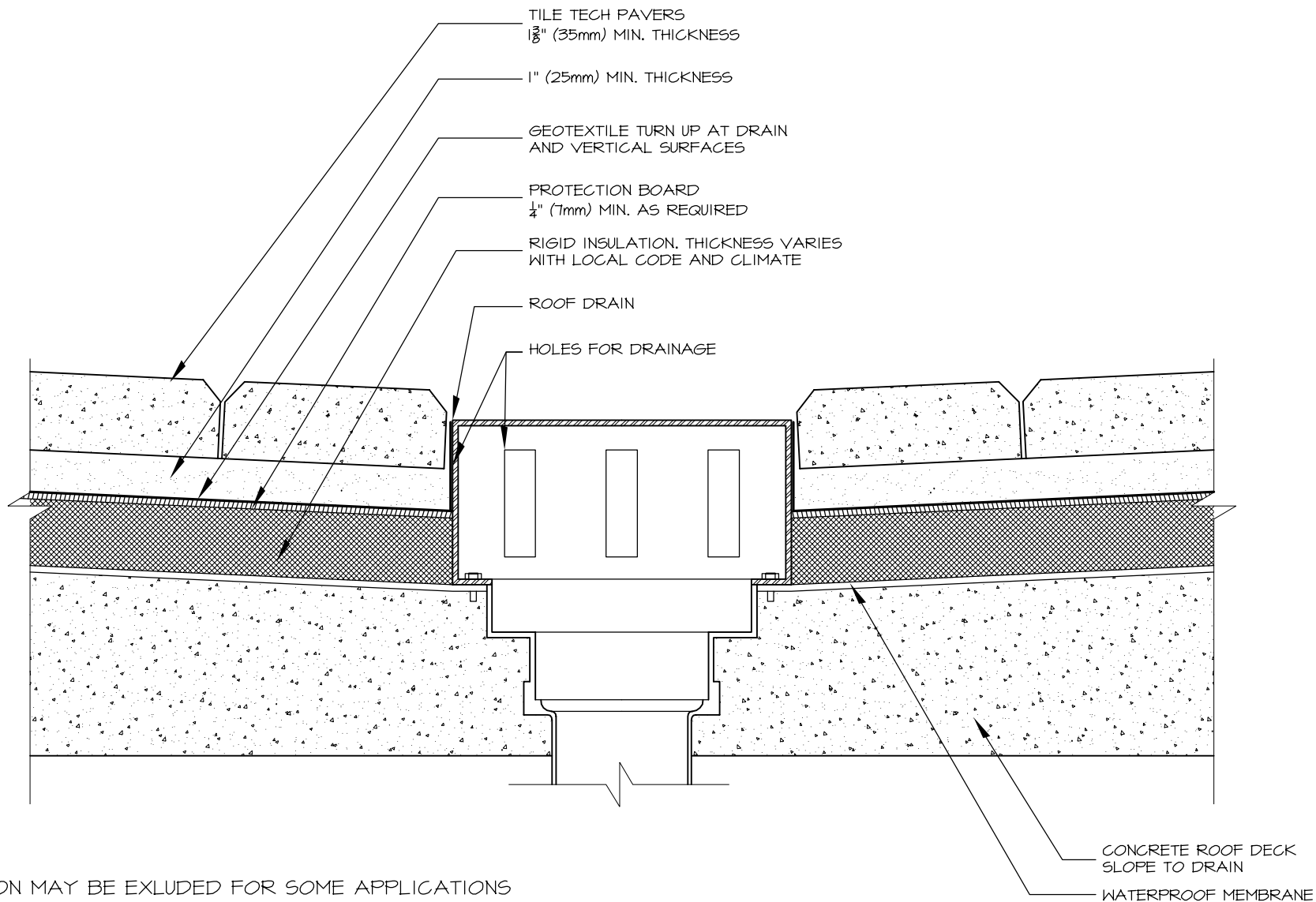

NOTES:

- 1. INSULATION MAY BE EXCLUDED FOR SOME APPLICATIONS
- 2. JOINTS SHOULD BE SWEEPED WITH SAND

ARCHITECTURAL PAVERS ROOF DECK INSTALLATION

DRAWN BY: O100 DESIGN

DATE DRAWN:

REVISION DATE:

DRAWING SCALE: N.T.S

ENGINEER SEAL:



P. O. BOX 5982
LOS ANGELES, CA 90055
TEL: 213-380-5560 FAX: 213-380-5561
www.TileTechPavers.com

NONE PEDESTAL

FIELD DETAILS

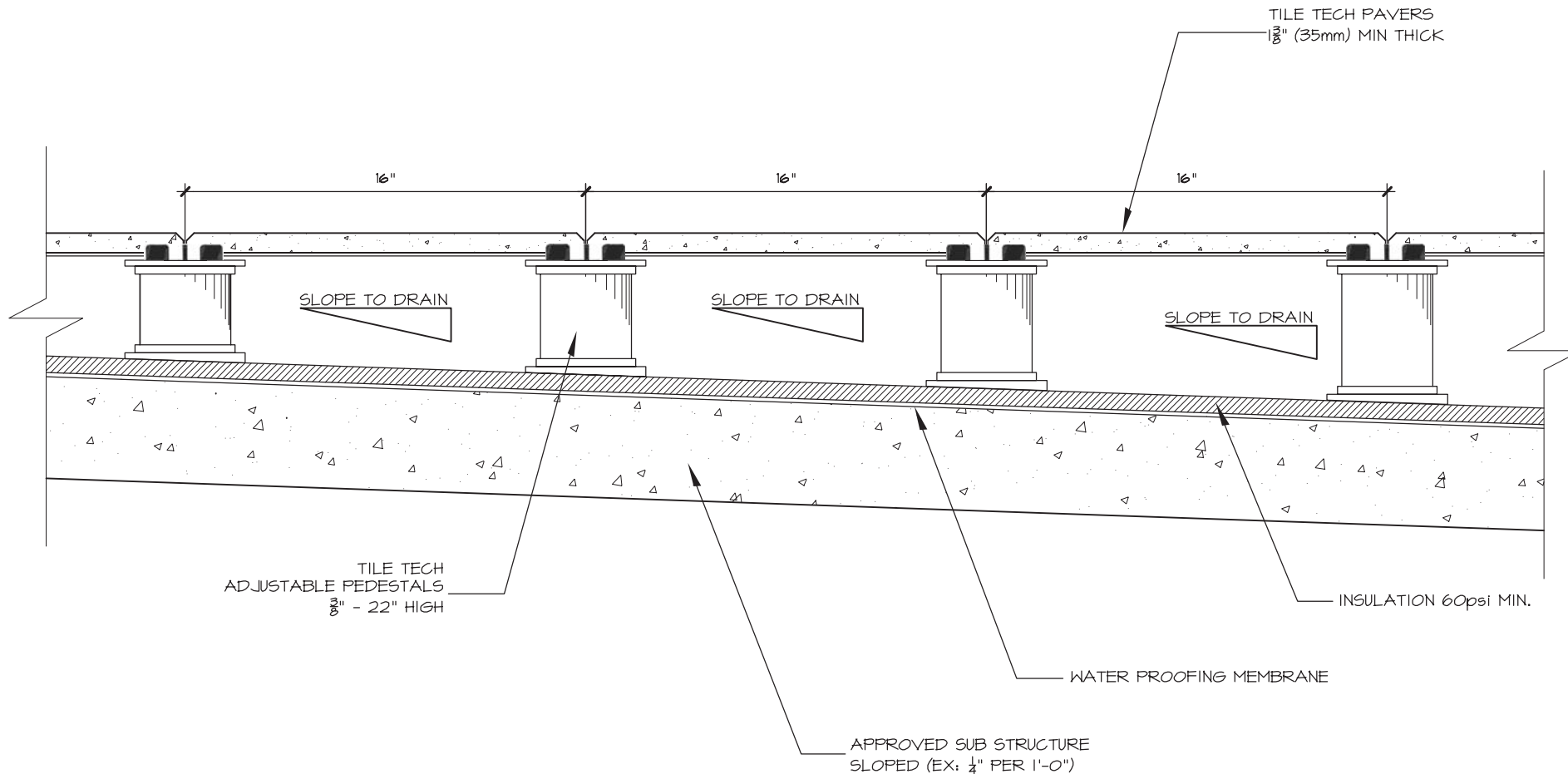

PEDESTAL PAVER SYSTEM ROOF DECK INSTALLATION

DRAWN BY: O100 DESIGN

DATE DRAWN:

REVISION DATE:

DRAWING SCALE: N.T.S

ENGINEER SEAL:



P. O. BOX 5982
LOS ANGELES, CA 90055
TEL: 213-380-5560 FAX: 213-380-5561
www.TileTechPavers.com

ADJUSTABLE HEIGHT
PEDESTALS

LEVEL SURFACE
OVER SLOPE

ROOF WALL JUNCTURE.

DECK RAIN.

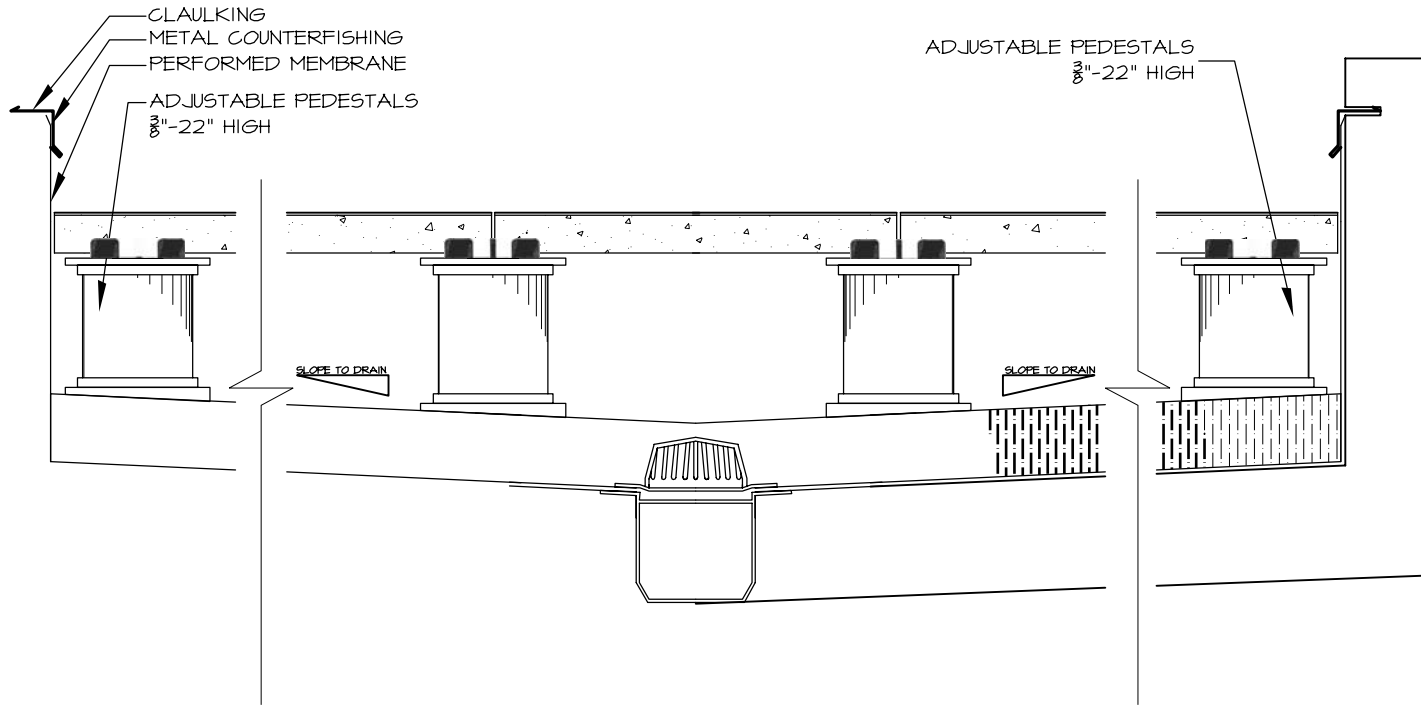

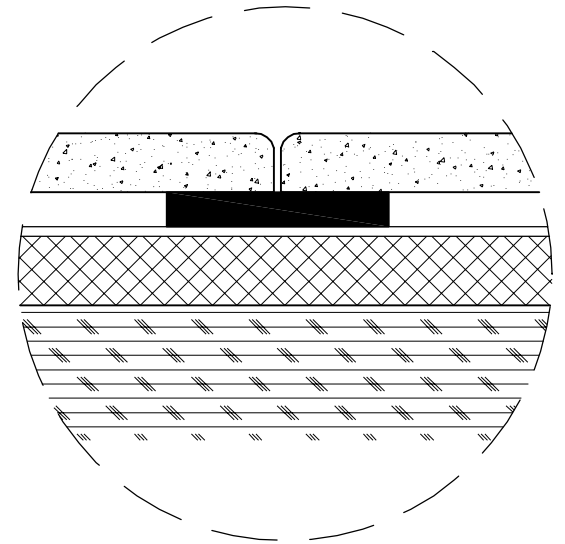
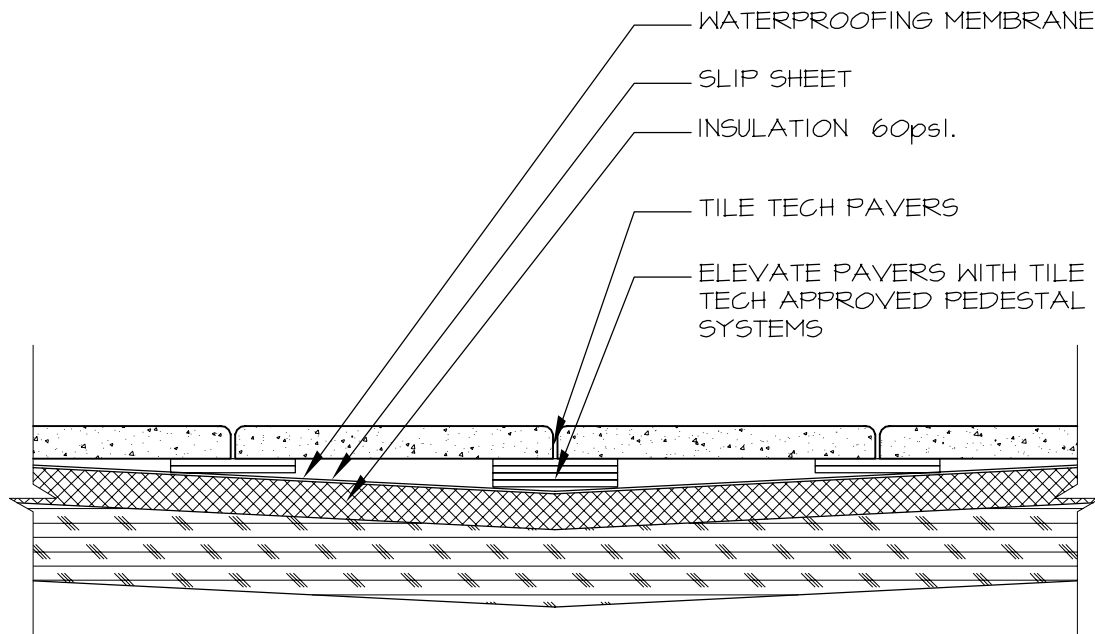

PEDESTAL PAVER SYSTEM INSTALLATION DETAILS

DRAWN BY: O100 DESIGN

DATE DRAWN:

REVISION DATE:

DRAWING SCALE: N.T.S



P. O. BOX 5982
 LOS ANGELES, CA 90055
 TEL: 213-380-5560 FAX: 213-380-5561
www.TileTechPavers.com

SLOPE DETAILS

LEVEL SURFACE
OVER SLOPE

ENGINEER SEAL:

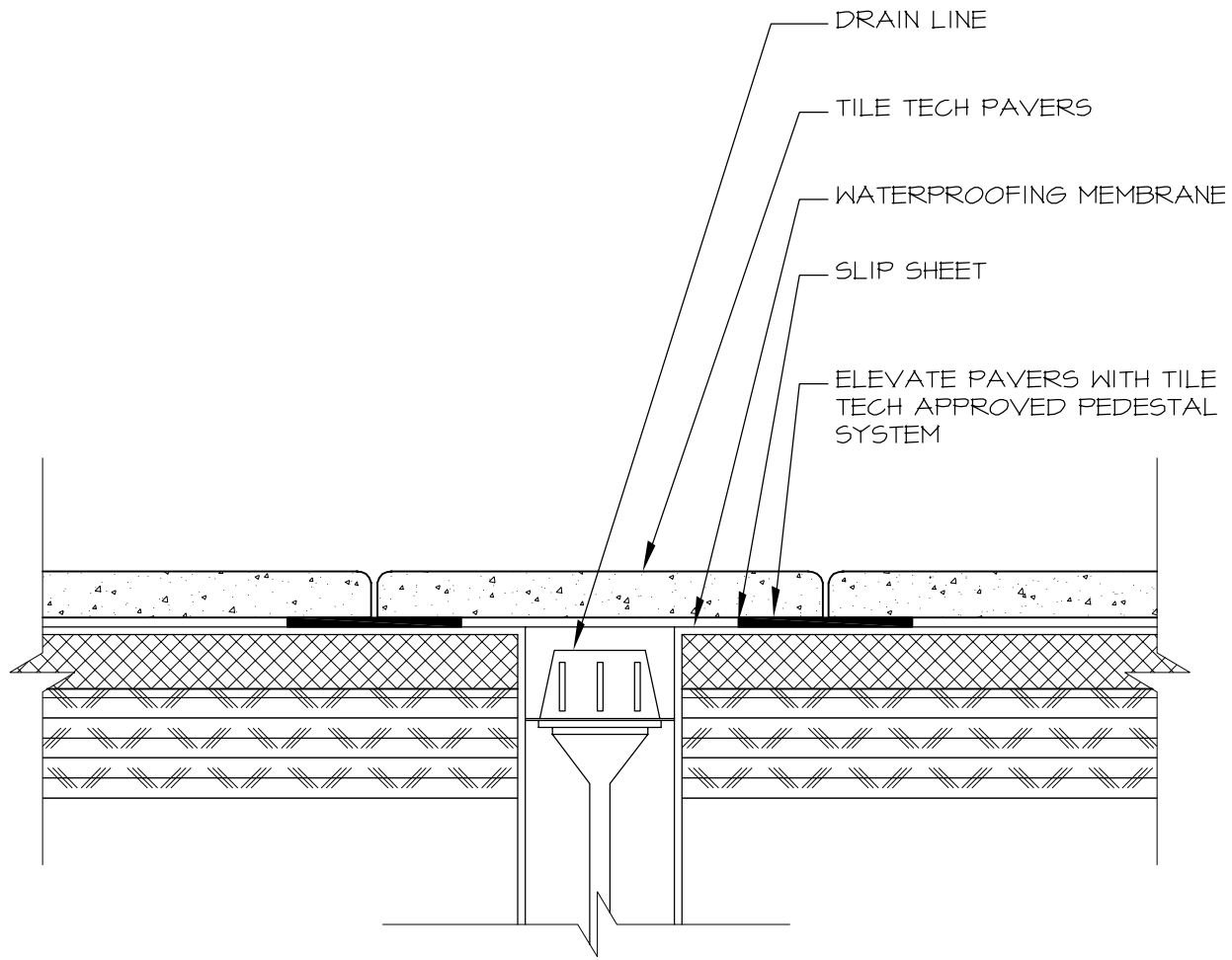

PEDESTAL PAVER SYSTEM INSTALLATION DETAILS

DRAWN BY: O100 DESIGN

DATE DRAWN:

REVISION DATE:

DRAWING SCALE: N.T.S



P. O. BOX 5982
LOS ANGELES, CA 90055
TEL: 213-380-5560 FAX: 213-380-5561
www.TileTechPavers.com

DRAIN DETAIL

TYPICAL

ENGINEER SEAL:

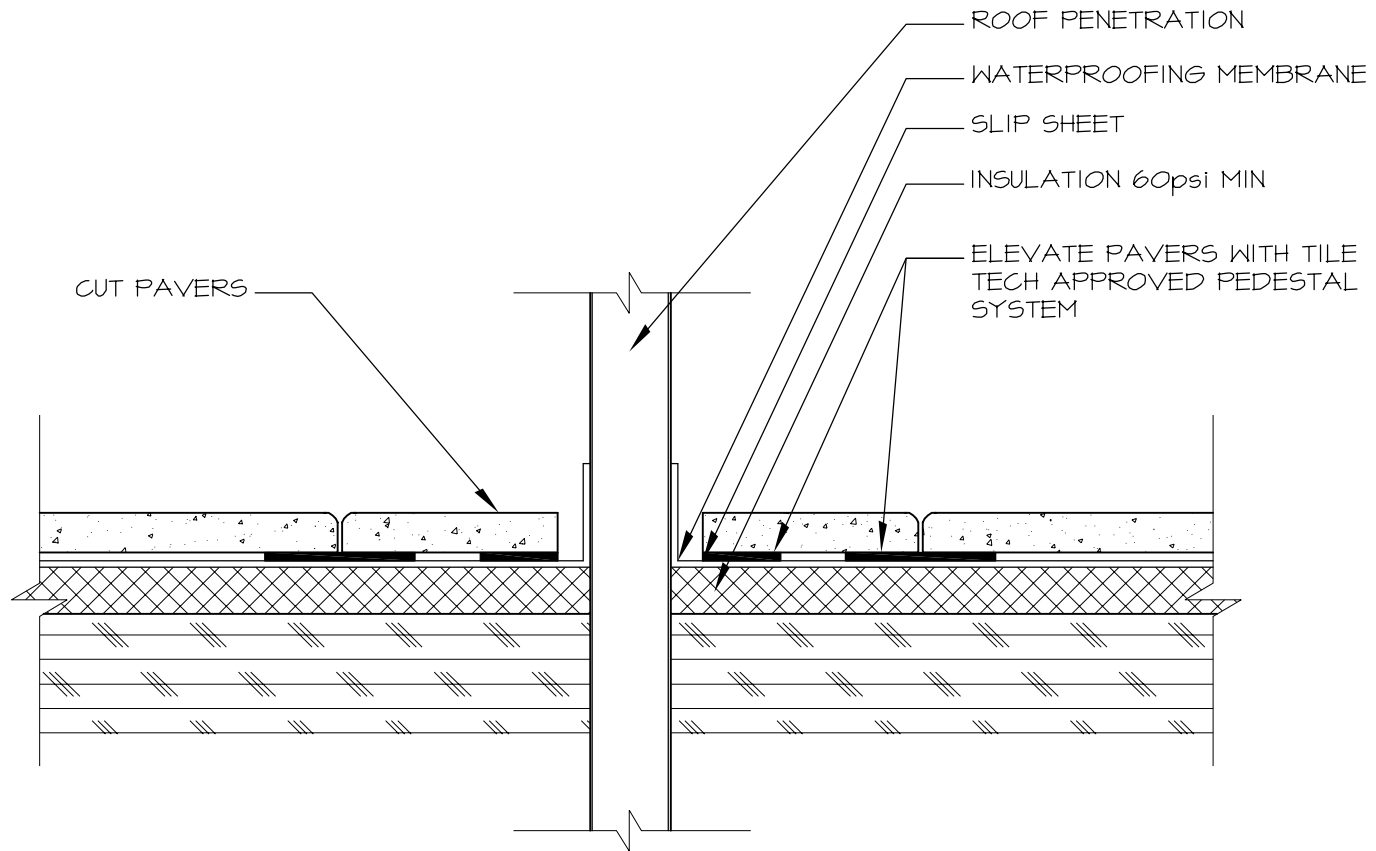

PEDESTAL PAVER SYSTEM INSTALLATION DETAILS

DRAWN BY: O100 DESIGN

DATE DRAWN:

REVISION DATE:

DRAWING SCALE: N.T.S



P. O. BOX 5982
LOS ANGELES, CA 90055
TEL: 213-380-5560 FAX: 213-380-5561
www.TileTechPavers.com

ROOF PENETRATION

TYPICAL

ENGINEER SEAL:

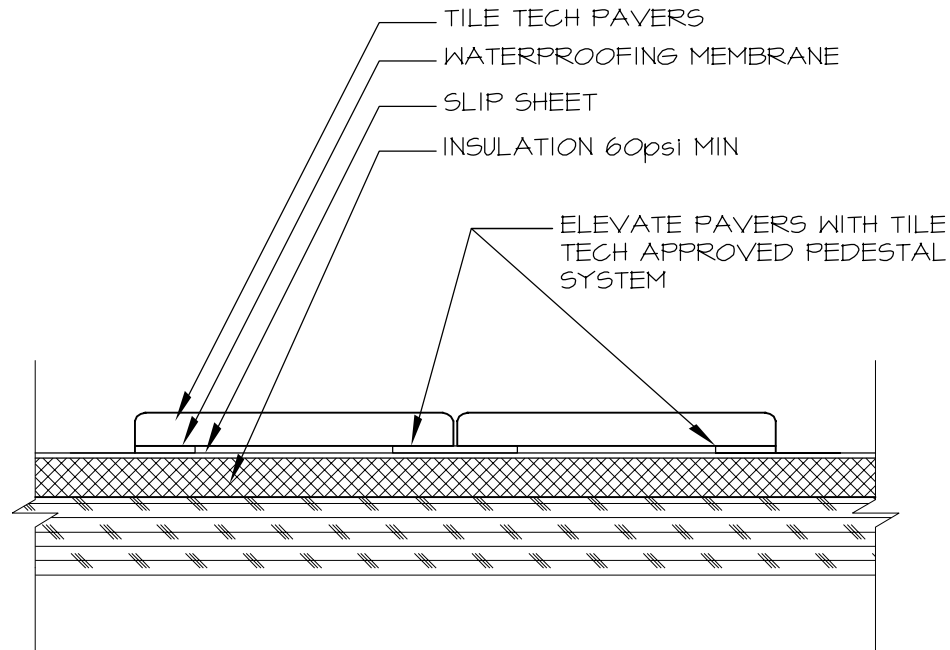

PEDESTAL PAVER SYSTEM INSTALLATION DETAILS

DRAWN BY: O100 DESIGN

DATE DRAWN:

REVISION DATE:

DRAWING SCALE: N.T.S



P. O. BOX 5982
LOS ANGELES, CA 90055
TEL: 213-380-5560 FAX: 213-380-5561
www.TileTechPavers.com

PERIMETER BALLAST
AND WALKWAYS

ENGINEER SEAL:

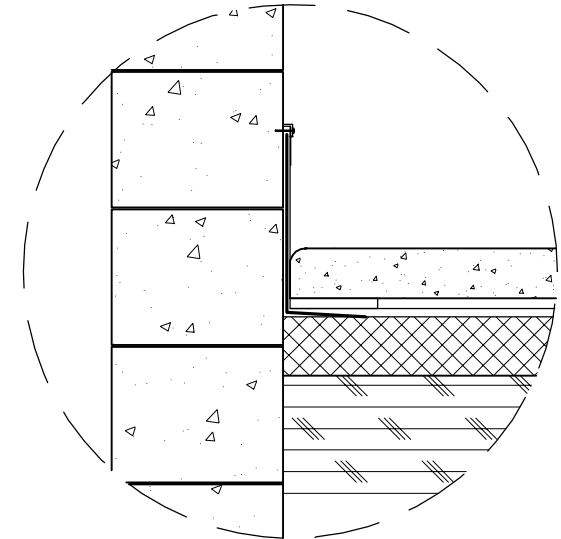
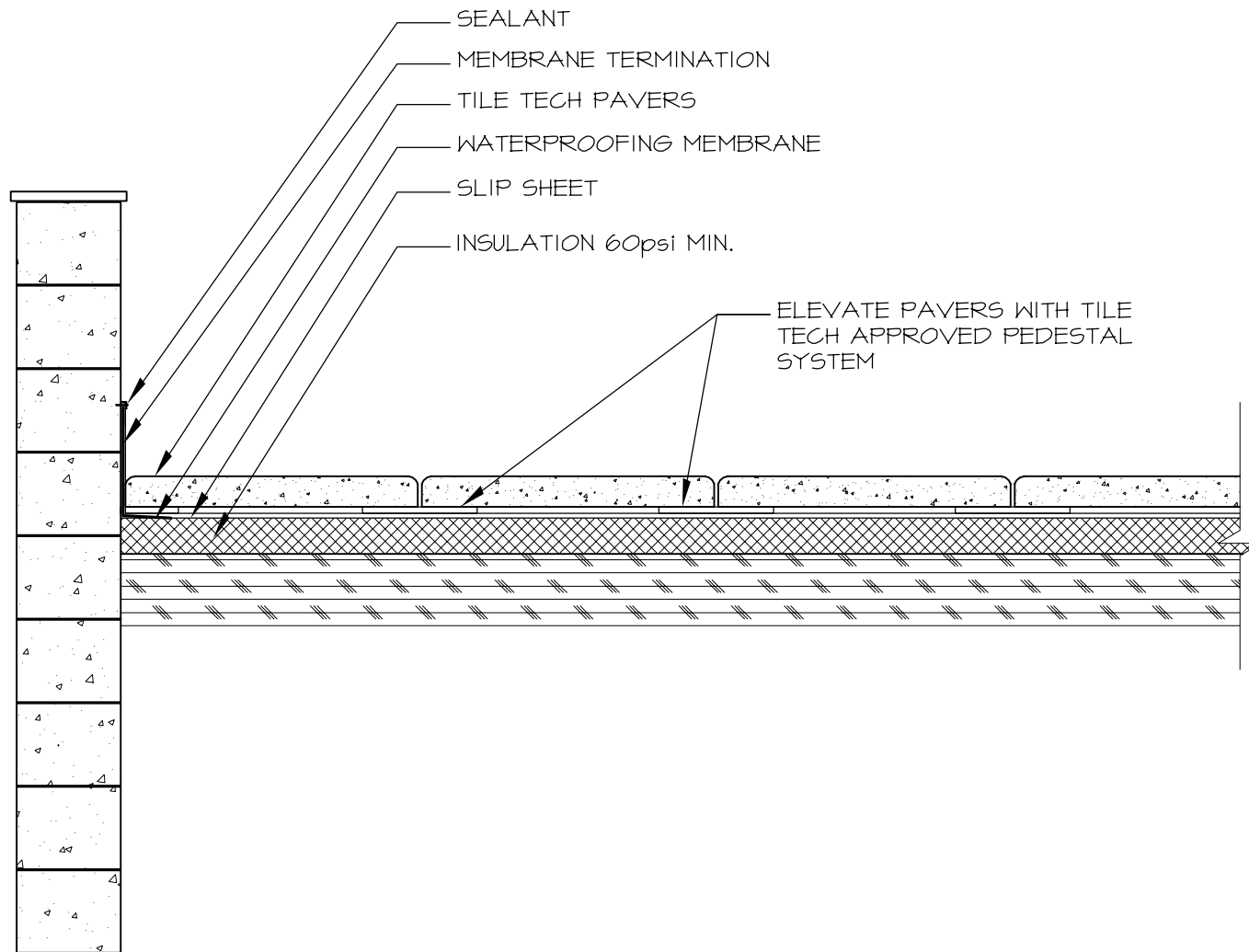

PEDESTAL PAVER SYSTEM INSTALLATION DETAILS

DRAWN BY: O100 DESIGN

DATE DRAWN:

REVISION DATE:

DRAWING SCALE: N.T.S

ENGINEER SEAL:



P. O. BOX 5982
LOS ANGELES, CA 90055
TEL: 213-380-5560 FAX: 213-380-5561
www.TileTechPavers.com

EDGE DETAIL

PARAPET
TERMINATION
(PART 1)

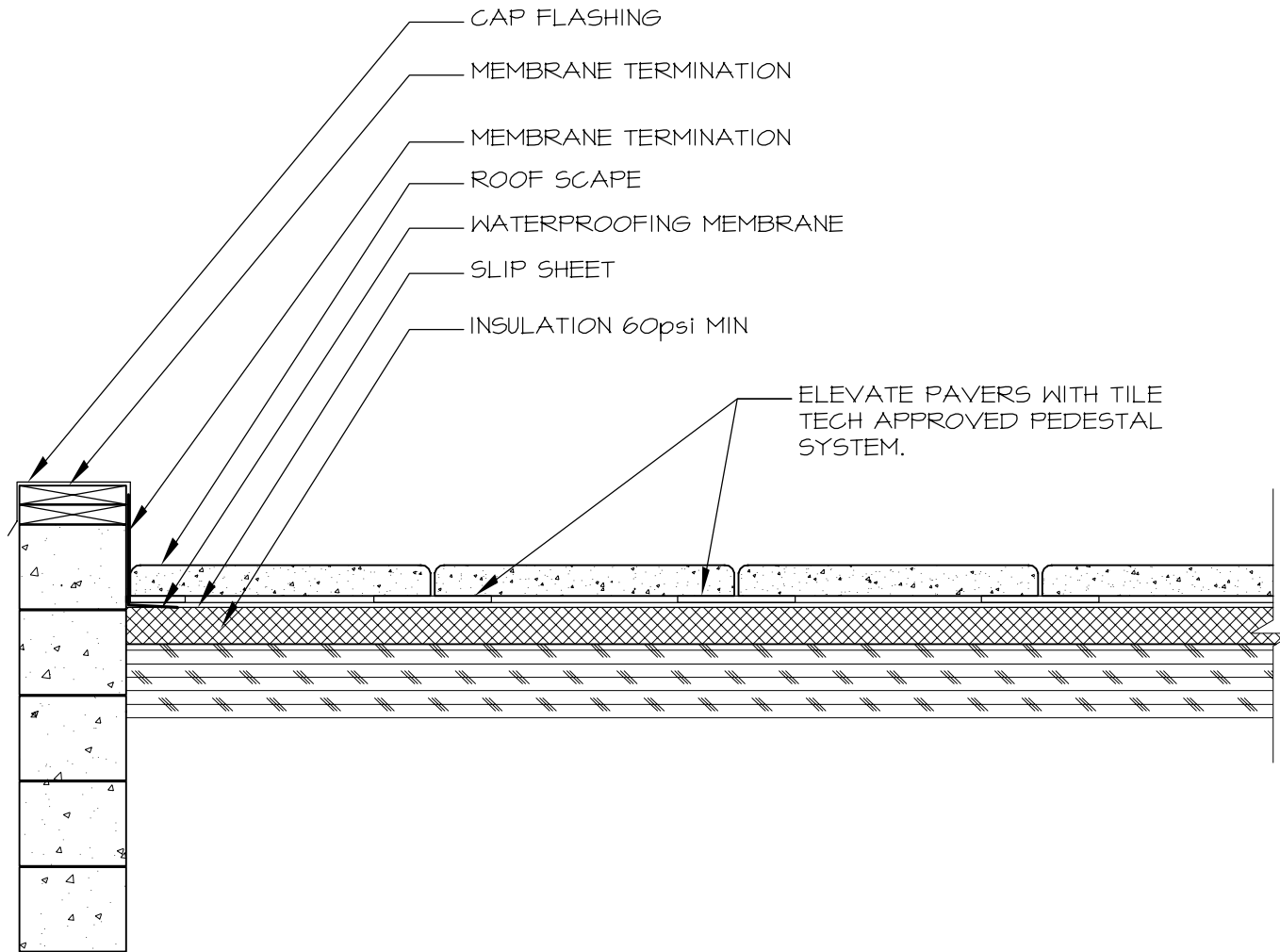

PEDESTAL PAVER SYSTEM INSTALLATION DETAILS

DRAWN BY: O100 DESIGN

DATE DRAWN:

REVISION DATE:

DRAWING SCALE: N.T.S



P. O. BOX 5982
LOS ANGELES, CA 90055
TEL: 213-380-5560 FAX: 213-380-5561
www.TileTechPavers.com

EDGE DETAILS

PARAPET
TERMINATION
(PART 2)

ENGINEER SEAL:

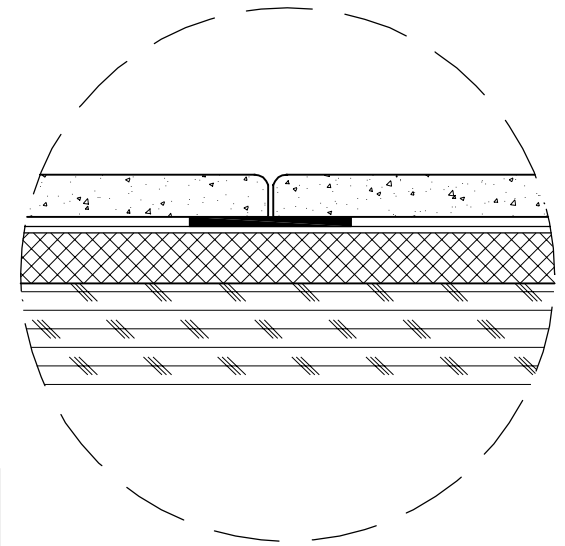
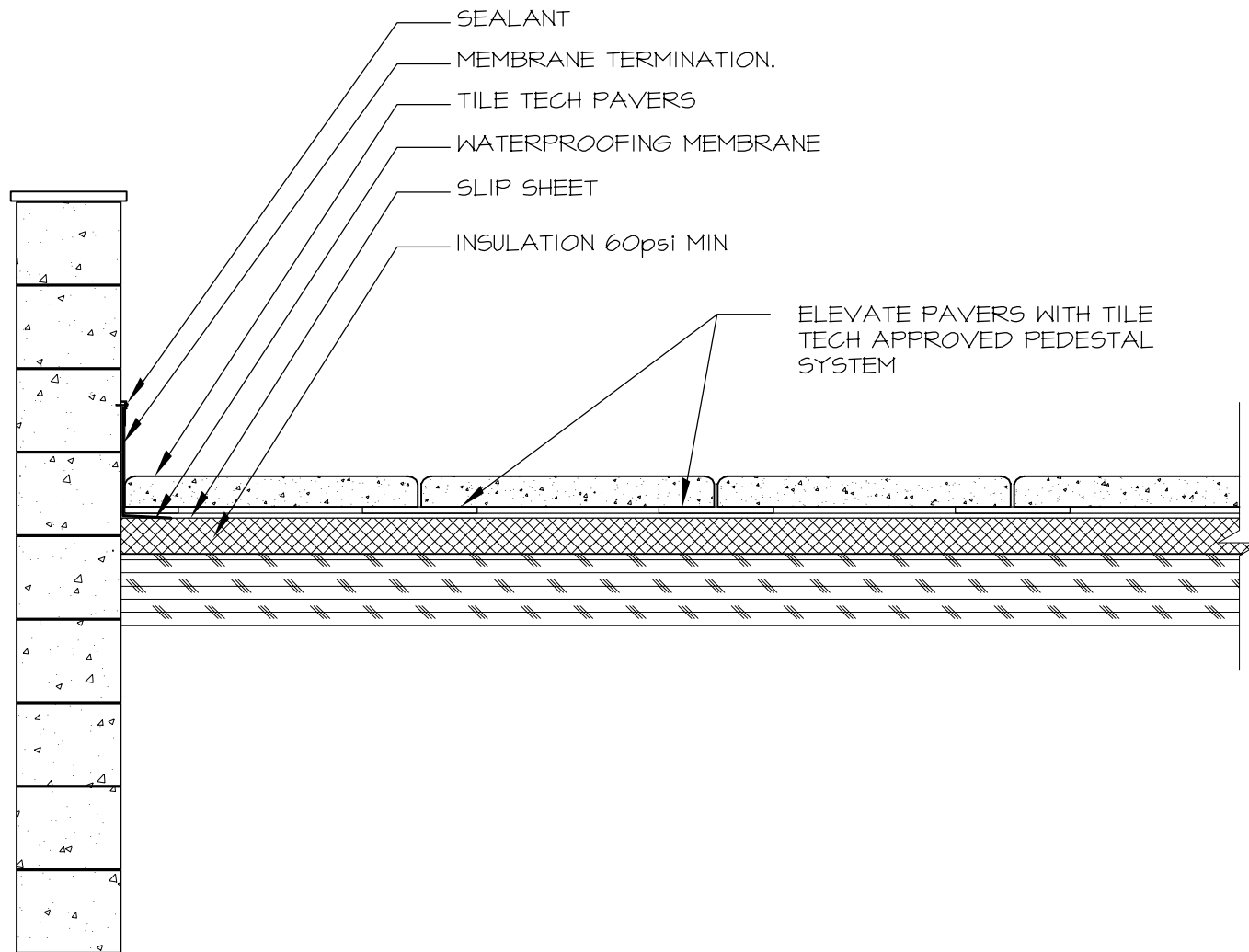

PEDESTAL PAVER SYSTEM INSTALLATION DETAILS

DRAWN BY: O100 DESIGN

DATE DRAWN:

REVISION DATE:

DRAWING SCALE: N.T.S

ENGINEER SEAL:



P. O. BOX 5982
LOS ANGELES, CA 90055
TEL: 213-380-5560 FAX: 213-380-5561
www.TileTechPavers.com

EDGE DETAILS

PARAPET
TERMINATION
(PART 3)